



PANGEN[®] SYSTEM WARRANTY

Warranty Guide

PROGRAM OUTLINE**TABLE OF CONTENTS:**

<u>MATERIALS</u>	<u>PAGE #</u>
Program Outline	2
• Table of Contents	
Warranty Information	3
• Introduction & Installation Locations	
• Filing Warranty Claim	
Appendix A, System Warranty Documentation Requirements	
• Documentation requirements for the Warranty Registration process	4 - 5
Appendix B, Definitions	
• Definition of specific terms or phrases used throughout the PanGen [®] System Warranty Program	6 - 7
Appendix C, Commercial Building Telecommunications Cabling Standards	
• List of internationally and regionally recognized standards	8
Appendix D, System Warranty Claim Form	
• Blank form used for submitting a warranty claim	9

WARRANTY INFORMATION

Introduction

The PanGen® System Warranty provides customers with the confidence and security of knowing that their cabling system will deliver the performance they expect to meet their long term networking needs.

The program offers a 25-year standards based performance warranty that applies to all registered links and/or channels in an installation. The program guarantees that these registered links and/or channels will meet minimum performance requirements as specified in the Commercial Building Telecommunications Cabling Standards, which are listed on Appendix C of this Warranty Guide. With this baseline of performance, customers are assured that their cabling system will support current and future networking applications designed to run on their cabling system.

If these registered links and/or channels fail to meet the specified performance requirements, the warranty covers the repair or replacement of defective connectivity hardware and/or cable, including, the cost of the labor associated with this repair or replacement per the terms of the warranty.

In addition, the program provides one point of contact for system issues, simplifying issue resolution. For customers, the one point of contact is their original Panduit ONESM Enterprise Structured Cabling Deployment Partner (“Partner”).

Requirements of the program include verified compliance with design, installation, operation, and maintenance practices as well as test, labeling and administration procedures as specified in the Commercial Building Telecommunications Cabling Standards. These requirements help ensure that all links and/or channels will support expected performance requirements and help facilitate easy moves, adds, and changes, decreasing the customers’ overall cost of ownership over time.

Installation Locations

The PanGen® System Warranty is only applicable for commercial building applications and is not authorized for residential (personal, family or household) applications. The warranty is immediately void for any structured cabling system, which is found to be installed in a residential application.

Filing Warranty Claim

Use the PanGen® System Warranty Claim Form (Appendix D), if you experience problems and believe the Panduit connectivity hardware and/or General Cable’s PanGen® cable are the cause. You must notify Panduit within 10 business days of the original problem.

APPENDIX A --SYSTEM WARRANTY DOCUMENTATION REQUIREMENTS

In order for the structured cabling system or additional links and/or channels to be eligible for warranty coverage the following documentation must be submitted by the installer to Panduit:

Requirements	Typical format or additional explanation of information to be submitted
<p>A certified passing test report for each link and/or channel must be submitted to and received by Panduit Corp. no later than 6 months after the last date of testing is complete for the installation. Panduit will not issue a warranty for an installation whose last testing date is older than 6 months. In such case, you will be required to retest all links and channels and submit new test reports in order to receive a warranty for that entire installation.</p> <p>A certified passing test report for each link and/or channel must be submitted to and received by Panduit Corp. prior to the date the warranty is issued.</p> <p><u>Each certified test report must clearly indicate:</u></p> <ol style="list-style-type: none"> 1. Date the test was conducted. 2. For fiber installations, a passing test report for each reference cord must be submitted in accordance with the requirements set forth on Exhibit 1 to this Appendix A. See “Testing Requirements for Fiber Links” on Exhibit 1 of this Appendix A. 3. The designated link and/or channel performance level (i.e. Category 3, Category 5, Class C, Category 5e, Class D, Category 6, Class E, Category 6, Class EA, Category 6A, Class EA, Multimode or Singlemode) and the link configuration (permanent link or channel). 4. A link identifier in compliance of ANSI/TIA-606-B and ISO/IEC 14763-2-1. 5. A “PASS” or “*PASS” test result for the overall test requirements specified in the Commercial Building Telecommunications Cabling Standards for each designated link and/or channel classification. 6. For fiber installations only, no negative loss values will be accepted as a “PASS” test result. 7. The installation project name. 8. The test equipment manufacturer, test equipment model and test equipment test cord adapter part number. <p>Any link and/or channel, which are not identified in a certified passing test report, will not be covered by this warranty.</p>	<p>A certified passing test report is one that has been verified by the installer.</p> <p>Test reports generated by standard field test equipment must list all necessary performance results as specified in the Commercial Building Telecommunications Cabling Standards for the designated link and/or channel performance level (i.e. Category 3, Category 5, Class C, Category 5e, Class D, Category 6, Class E, Category 6, Category 6A, Class EA.</p> <ul style="list-style-type: none"> • All information must be uploaded to The Hub and must come in the field tester manufacturers’ standard file format. Please contact the Panduit Warranty Department, if you are unsure of the correct file format. warranty@panduit.com. • Each test report must contain a clear distinct designated link or channel classification (i.e. Category 3, Category 5, Class C, Category 5e, Class D, Category 6, Class E, Category 6A, Class EA, Multimode or Singlemode). No alternate or added descriptions. An “*” (asterisk) i.e. *Pass preceeding a passing test result can be considered acceptable as long as it meets minimum compliance to the cabling standards. • Each optical fiber link test report must include both <u>link loss and length</u> in order to verify compliance to the cabling standards.

APPENDIX A --SYSTEM WARRANTY DOCUMENTATION REQUIREMENTS

Reference Information –

- Must show the designated standard classification for each link and/or channel and the specific component and cable part numbers used for the link and/or channel.
Note: To qualify for a Certification PlusSM System Warranty, each registered cable link and/or channel must be 100% constructed of Panduit connectivity hardware and General's PanGen approved cable as classified by Panduit and General Cable Company.
- Must include the link identifier marked on each corresponding work area connector, telecommunication closet connector and/or patch panel which corresponds to the particular link identifier (circuit ID) on the test report. Link identifiers must be formatted in accordance with ANSI/TIA-606-B and ISO-IEC 14763-2-1.

Must indicate the identification of the building (for campuses), floor, room, outlet, and port number for the work area. For the telecommunications closet, the reference should indicate identification of the closet; patch panel, and port number of the patch panel.

APPENDIX A --SYSTEM WARRANTY DOCUMENTATION REQUIREMENTS

EXHIBIT 1 -Testing Requirements for Fiber Links

1. Reference utilizing method B (One Jumper Reference). Note: RX test head on test units shown as LC.

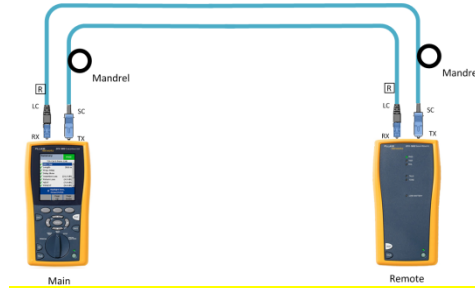

2. After referencing (Results between -22dB and -24dB for MM and -6dB and -8dB for SM). Add LC to LC reference cords and test them to ensure they are less than or equal to 0.15dB standard for IL for MM and 0.25dB or less for SM). Save the test result as Ref 1, Ref 2. If you re-reference for any reason, re-save the values as Ref 3, Ref 4...etc...until testing is complete.

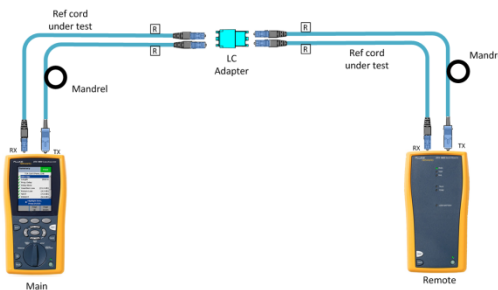

APPENDIX B – DEFINITIONS AND TERMINOLOGY

CABLE	An assembly of one or more conductors or optical fibers within an enveloping sheath, constructed so as to permit use of the conductors singly or in groups. The Commercial Building Telecommunications Cabling Standards must approve them.
COMMERCIAL BUILDING TELECOMMUNICATIONS CABLING STANDARDS	Commercial building telecommunication wiring standards that are used to design, install and test structured cabling systems. Refer to Appendix C for a complete list of standards Groups (1, 2, 3, etc.) that can be used with this program.
CONNECTIVITY HARDWARE	Passive copper and optical fiber connectors and adapters, patch cords, modules, patch panels, cable management and related mounting hardware.
CUSTOMER	The end user company that has hired the Partner to install a structured cabling system. If approved, Panduit will issue the PanGen® System Warranty directly to the Customer.
DESIGNATED LINK AND/OR CHANNEL CLASSIFICATION	The link and/or channel category or classification defined in the applicable Commercial Building Telecommunications Cabling Standards used to indicate the link and/or channel's minimum performance. A link and/or channel category or classification must be verified through a passing test report.
ENTERPRISE STRUCTURED CABLING DEPLOYMENT PARTNER OR "PARTNER"	A structured cabling system installation company that meets the requirements of and is registered and approved by Panduit as a Panduit Enterprise Structured Cabling Partner accredited in the Deploy Competency in the Panduit ONE SM Partner Program and is authorized to submit installations to Panduit for PanGen® System Warranties.
PANDUIT ENTERPRISE STRUCTURED CABLING CERTIFIED TECHNICIAN	A technician employed by the Partner on a full-time basis who has passed the required training courses and who has a current Partner Employee Training certificate for Enterprise Structured Cabling that is not expired or suspended.
STRUCTURED CABLING SYSTEM	A group of links.

APPENDIX B – DEFINITIONS AND TERMINOLOGY

COPPER LINK

A passive communication transmission path, which is composed exclusively of Panduit connectivity hardware and General Cable’s PanGen® cable and performs to the Commercial Building Telecommunications Cabling Standards. This transmission path includes copper connectivity hardware and copper cabling or optical fiber connectivity hardware and optical fiber cabling. See Interconnection diagram below.

PERMANENT LINK

A horizontal link which includes cable, a telecommunication work area outlet/connector, an optional transition connection close to work area, and a single horizontal cross-connect connection in the telecommunication closet. See Interconnection diagram below. See Interconnection diagram below.

Interconnection

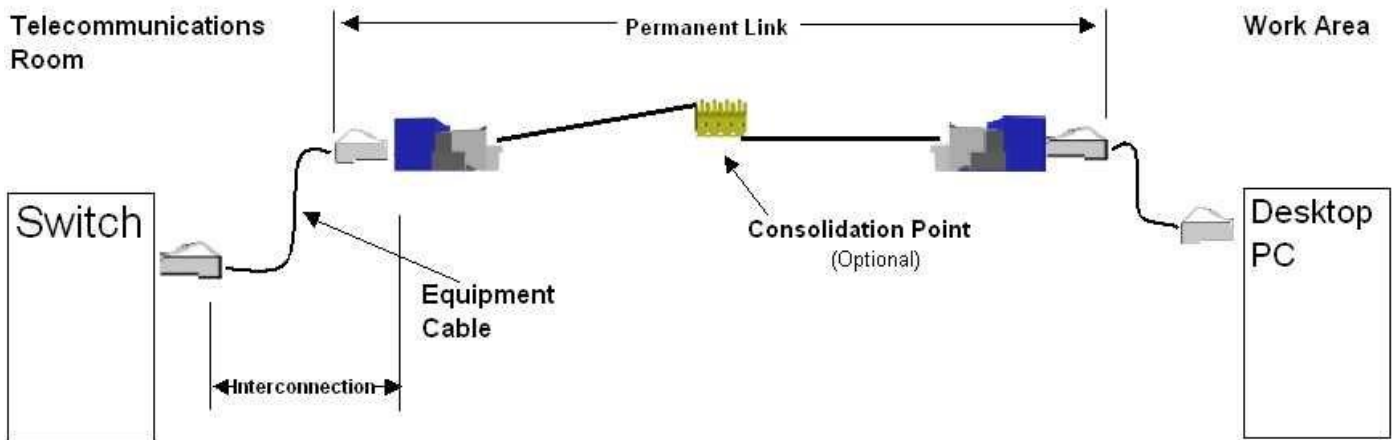

Refer to TIA-568-C.1
Section 9, Figure 6

APPENDIX B – DEFINITIONS AND TERMINOLOGY

COPPER CHANNEL

A horizontal link which includes cable, work area equipment cord, a telecommunication work area outlet/connector, an optional transition connection close to work area, and two cross-connect connections in the telecommunication closet. See Cross-connection diagram below.

Cross-connection

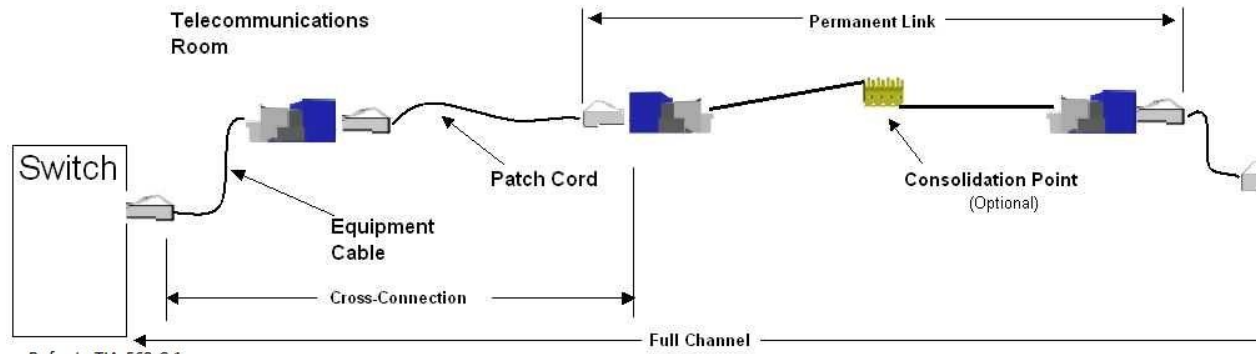

Refer to TIA-568-C.1
Section 9, Figure 7

APPENDIX B – DEFINITIONS AND TERMINOLOGY

FIBER LINK - ISO/IEC and TIA standards define a Link as the permanent fiber cabling infrastructure over which the active equipment must communicate. This does not include equipment patch cords to connect the active network devices in equipment distribution areas or the patch cords in the cross connect patch areas (see dashed lines in figure below).

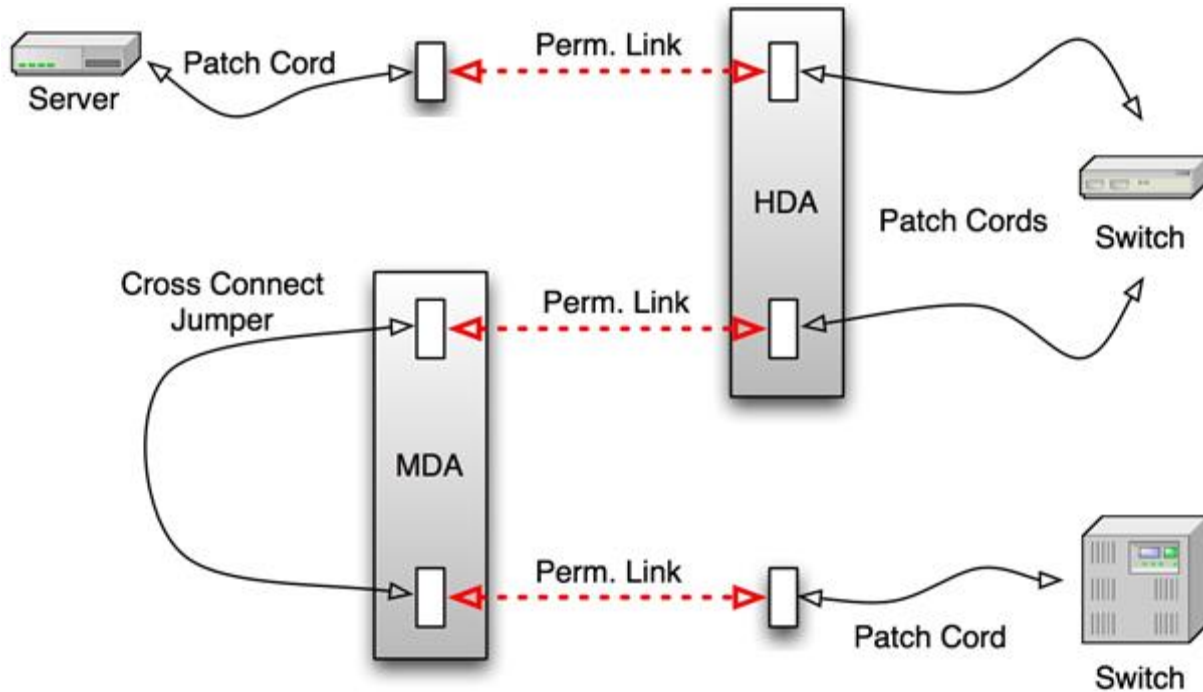

ISO/IEC and TIA standards define Link testing to verify the performance of the fixed (permanent) segments of installed cabling as accurately as possible.

Completion of this testing provides assurance that permanent links that pass standards-based (or application-based) limits can reliably be configured into a passing Channel by adding good quality patch cords.

APPENDIX C

COMMERCIAL BUILDING TELECOMMUNICATIONS CABLING STANDARDS

To be eligible for the PanGen® System Warranty the following Commercial Building Telecommunications Cabling standards (and their subsequent revisions) must be used for the design, installation and maintenance of the structured cabling system except where authorized in writing by Panduit.

Group 1 - North America and Other International Regions –

- 1) ANSI/TIA-568-0-D, Generic Telecommunications Cabling for Customer Premises August, 2012
- 2) TIA-568-C.1-1, Commercial Building Telecommunications Cabling Standard, May, 2012
- 3) ANSI/TIA-568-C.2, Balanced Twisted-Pair Telecommunications Cabling and Components Standards, August, 2009
- 4) ANSI/TIA-568-C.3-1, Optical Fiber Cabling Components Standard, December, 2011.
- 5) TIA-569-C-1, Commercial Building Standard for Telecommunications Pathways and Spaces, February, 2013.
- 6) TIA-606-B, Administration Standard for Commercial Telecommunications Infrastructure, June, 2012

Group 2 – ISO/IEC Europe and Other International Regions –

- 1) ISO/IEC 11801-1:2017 ed2.2 Consol. with am1&2 (2011-06)
- 2) ISO-IEC 14763-2-2012 Implementation and operation of customer premises cabling – Part 2: planning and installation.

Group 3 – AS/NZS Australia and New Zealand –

- 1) AS/NZS 3080:2013 Information technology - Generic cabling for customer premises (ISO/IEC 11801:2011, MOD)
- 2) AS/NZS 3084:2017/Amdt 1:2007 Telecommunications installations - Telecommunications pathways and spaces for commercial buildings (ISO/IEC 18010:2002, MOD)
- 3) AS/NZS 3085.1:2004 Telecommunications installations - Administration of communications cabling systems - Basic requirements
- 4) AS/NZS ISO/IEC 14763.3:2012 Telecommunications installations - Implementation and operation of customer premises cabling - Testing of optical fibre cabling (ISO/IEC 14763-3:2011, MOD)
- 5) AS/NZS IEC 61935.1:2012 Specification for the testing of balanced and coaxial information technology cabling - Installed balanced cabling as specified in ISO/IEC 11801 and related standards (IEC 61935-1, Ed.3.0 (2009) MOD)

APPENDIX C
COMMERCIAL BUILDING TELECOMMUNICATIONS CABLING STANDARDS

SUPPORT DOCUMENTATION

1) BICSI Telecommunications Distribution Methods Manual

Note:

- The use of any other standards other than those listed above must be reviewed and pre-approved by Panduit.
- In the event that a conflict arises as to which standards group was used for the design, installation and maintenance of the structured cabling system, the Group 1 standards shall be the controlling standard.

APPENDIX D --- WARRANTY CLAIM FORM

Claim Date: _____
Warranty Registration #: _____ Installation Date: _____
Claim Initiator: _____ Initiator's Phone #: _____
(Name of individual submitting the claim form)
Claim Initiator Company: _____ Initiator's Fax #: _____

INSTALLER

Company Name: _____
Address _____
City: _____ State: _____ Postal Code: _____
Contact Name: _____ Title: _____
Phone: _____ Fax: _____

CUSTOMER

Company Name: _____
Address _____
City: _____ State: _____ Postal Code: _____
Contact First Name: _____ Contact Last Name: _____ Title: _____
Phone: _____ Fax: _____

Please include a brief explanation of the system problem and the reason why you believe the problem is caused by Panduit connectivity hardware and/or General Cable's PanGen® cable. Must notify Panduit within 30 business days of original problem.

Comments: _____

E-mail the completed form with an explanation to:

Warranty@panduit.com